



Björnsdóttir, Sigríður Mjöll. 2023. Predicting ineffability: Grammatical gender and noun pluralization in Icelandic. *Glossa: a journal of general linguistics* 8(1). pp. 1–40. DOI: <https://doi.org/10.16995/glossa.5823>



Open Library of Humanities

Predicting ineffability: Grammatical gender and noun pluralization in Icelandic

Sigríður Mjöll Björnsdóttir, Department of Linguistics, University of Konstanz, DE, sigridur.bjoernsdottir@uni-konstanz.de

The structure of inflectional paradigms is characterized by interdependencies between forms and categories. The question is what the nature of these interdependencies are and how they are discovered in acquisition. In this article, I approach these issues from a learning perspective using gender and plural formation in Icelandic as a case study. Specifically, I investigate how knowledge of grammatical gender facilitates the induction of plural forms or vice versa. Noun pluralization in Icelandic cross-cuts both gender and inflection classes, raising the question of how children can extract the relevant generalizations given syncretism both within and across inflectional paradigms. In a corpus study, I show how predictions regarding the productivity of correspondences between gender and plural forms in Icelandic can be formulated by the Tolerance Principle, a learning model proposed by Yang (2005; 2016). The model centers around a threshold function that predicts the division line between productive and unproductive linguistic patterns in language based on the proportion of exceptions associated with any given pattern. These predictions were put to the test in two elicited production studies on both children and adults. I demonstrate how both children and adults were at a loss to pluralize nouns that they were unable to assign gender to. Thus, productivity in gender assignment correlated with productivity in plural formation. Since knowledge of gender is contingent on the knowledge of productive nominative singular forms, I propose that gender may be a developmental prerequisite for the acquisition of plural formation in Icelandic due to the statistical primacy of singular forms in the input. I argue that gaps within the inflectional paradigm of Icelandic nouns follow naturally from a learning process guided by productivity that fails and results in rote memorization.

Glossa: a journal of general linguistics is a peer-reviewed open access journal published by the Open Library of Humanities. © 2023 The Author(s). This is an open-access article distributed under the terms of the Creative Commons Attribution 4.0 International License (CC-BY 4.0), which permits unrestricted use, distribution, and reproduction in any medium, provided the original author and source are credited. See <http://creativecommons.org/licenses/by/4.0/>.

OPEN ACCESS



1. Introduction

Inflectional morphology has been at the heart of the debate regarding the nature of generalizations in language acquisition, with the English past tense serving as the main empirical battleground (see, among many, Pinker 1999). The main point of contention has been whether children store linguistic patterns in a rule-based or gradient fashion with divergent findings and conclusions (e.g. Clahsen 1999; Pinker 1999; Tomasello 2003). However, morphological systems vary along a great many dimensions, raising the need for cross-linguistic studies. Fusional morphological systems have raised interesting questions regarding how linguistic patterns are acquired and represented in the mind as in such cases there may be multiple productive patterns attested in the face of idiosyncrasies. The question is how young children can tease apart generalizations from idiosyncrasies in morphological systems based on the input data (see e.g. Dabrowska 2001; 2005 for Polish noun inflection). Furthermore, linguistic patterns within such systems are typically characterized by nested dependency relations such that knowledge of one linguistic pattern may be contingent on the knowledge of another (see, among many, Ackerman et al. 2009). As a consequence, children acquiring such morphological systems not only need to learn the individual forms and categories – they also need to learn how they interact with one another – in order to be able to inflect novel nouns. The question is how children learn these interdependencies and whether some generalizations may be a developmental prerequisite for learning others – and if so – why?

In this article, I provide the acquisition of grammatical gender and plural formation in Icelandic as a case study to illustrate the role of productivity in children's acquisition of dependency relations between linguistic categories, using corpus-based and experimental methods. Nouns in Icelandic encode grammatical gender, case and number. The interaction of these categories results in nested patterns of inflection, standardly described as inflection or declension classes, sets of roots which members each share the same set of inflectional realizations (e.g. Kramer 2015: 67). Since noun pluralization cross-cuts both gender and inflection classes, it provides an ideal case study of how children discover linguistic categories and the interdependencies between them in spite of the fact that there is not always a one-to-one correspondence between morphosyntactic value and phonetic form.

It has long been observed that some inflectional categories or forms seem to carry more weight than others. For instance, some inflectional forms, like the third-person singular in Spanish, have been claimed to play a privileged role in acquisition (Bybee and Brewer 1980; Bybee 1985). In parallel, certain forms of a paradigm seem to determine the direction of leveling. For example, Lahiri & Dresher (1983) discuss a number of case studies in which independently motivated sound changes in the nominative singular resulted in wholesale inflection shifts in Germanic. However, hitherto, it has been unclear why some inflectional forms, but not others, can induce changes to other inflectional realizations within the paradigm. A parallel

question has arisen with respect to the relation between the linguistic categories that make up an inflectional paradigm. For example, the role of grammatical gender in the acquisition of fusional noun inflection has been debated (see e.g. Mills 1986 and Spreng 2003 for German). Likewise, the role of grammatical gender versus inflection as catalysts for diachronic change in nominal morphology has been widely discussed (e.g. Berg 2019; Enger 2004; Wurzel 1987). These facts raise important questions regarding the nature of the interdependencies between linguistic categories in inflectional morphology and how they are established: Why do some forms and categories seem to carry more weight than others in acquisition and change? Does their privileged status somehow form part of the language design or do they arise from derivative factors such as frequency or language usage?

The interdependencies between linguistic categories, like gender and inflection, may differ cross-linguistically and under-go diachronic change (consult Kürschner, & Nübling 2011 for Germanic). For example, some languages, like Icelandic, have retained gender distinctions both in the singular and in the plural, while Danish has retained gender distinctions in the singular only (Hansen & Heltoft 2011). However, there is no language attested which encodes gender in the plural, but not in the singular, as stated by Greenberg 's (1966) universals 37 and 45. Given the language-specific nature of the interdependencies between linguistic categories, children must somehow discover whether the relation between forms or categories facilitates the induction of new forms in the target language or not.

In this article, I address these issues by asking how knowledge of grammatical gender facilitates the induction of plural formation in Icelandic. While many scholars have pointed out various correlations that may guide children's inferences about gender assignment, it has been unclear how these are discovered in acquisition. A prior study (Björnsdóttir 2021) illustrated how the conditions under which Icelandic-speaking children and adults generalized gender assignment to novel nouns could be predicted by a learning model (Yang 2016) in a corpus-based and experimental study. In the present study, I ask whether the same methods can predict the conditions under which children can predict plural forms in Icelandic. Furthermore, in a second corpus-based and experimental study, I ask whether the correlation between gender assignment and plural formation is unidirectional, or not.

First, I formulate predictions for productivity and absence thereof in the interdependencies between gender and plural suffixes in the Tagged Icelandic Corpus (Helgadóttir et al. 2012). Second, I put these predictions to the test in two elicited production studies that investigate the bidirectional relation between gender and plural formation in Icelandic. I demonstrate how children's knowledge of gender in Icelandic facilitates their inferences about plural forms. Conversely, I show how children's ineffability in gender assignment correlates with ineffability in plural marking.

What kind of information licenses the distribution of inflectional forms in inflectional morphology has been a matter of much debate in linguistic theory. For some approaches, inflection

classes are primitives of grammar (e.g. Matthew 1991; Stump 2001), whereas for others, they are epiphenomena (e.g. Bobaljik 2008). As a result, the nature of the generalizations underlying a speaker's ability to generate inflectional realizations for novel nouns and how these are formed in acquisition has been a matter of dispute. I argue that children's acquisition of inflectional paradigms is driven by a search for productive interdependencies between inflectional forms, guided by a learning model (Yang 2005; 2016). I further propose that findings from language acquisition and learning may shed light on the distribution of forms across the paradigms generated by the inflectional features of a language.

The article is organized as follows: In section two, I discuss prior approaches to paradigmatic relations and review contrastive arguments regarding the nature of the gender- inflection relation in grammar. Section three provides a description of gender and plural formation in Icelandic, followed by corpus analyses to generate predictions for learning in section four. Sections five and six lay out the methods and results of the experimental studies.

In section seven, I provide a general discussion of the findings and their theoretical implications. Section eight concludes this article.

2. Background

2.1 Discovering the distribution of inflectional forms

How do children construct hypotheses about inflectional patterns on the basis of the input, given the cross-linguistic diversity attested in inflectional morphology? In an influential line of work, Carstairs-McCarthy has proposed that the distribution of forms within an inflectional paradigm is constrained by a principle that seeks to prevent paradigm opacity, rooted in acquisition (Carstairs 1983; Carstairs-McCarthy 1987; 1994). The principle predicts that a word can only belong to a single inflection class and rules out paradigms with no unique inflectional features of their own. In its original version, the principle was stated as the Paradigm Economy Principle (Carstairs 1983). The principle states that there should be only one morphosyntactic value whose allomorph should be sufficient to predict the behavior of the entire paradigm. The later version, the No Blur Principle (NBP) states that each affix is either unique to a particular inflection class or the elsewhere default for the morphosyntactic value it realizes (Carstairs-McCarthy 1994).

Carstairs-McCarthy argues that the principle follows from a fundamental learning bias, the Principle of Contrast (PC) for lexical learning (Clark 1987; 1988; 1990). The PC is a pragmatic principle which states that "speakers take every difference in form to mark a difference in meaning" (Clark 1990: 64). However, at the outset, given the rampant syncretism attested in richly inflected languages, inflectional morphology seems to either invalidate the PC or suggest that the principle is irrelevant in the acquisition of inflectional morphology. Carstairs-McCarthy has attempted to reconcile the NBP with the PC by assuming that inflection class membership

can form part of the meaning of an affix. For example, the suffix *-ar* in Icelandic can either serve as a marker of the genitive singular or nominative plural for feminine nouns, as demonstrated in **Table 1** (from Carstairs-McCarthy 1994: 740)."

	Class A	Class B	Class C	Class D
GEN.SG	<i>-ar</i>	<i>-ar</i>	<i>-ar</i>	<i>-ur</i>
NOM.PL	<i>-ir</i>	<i>-ar</i>	<i>-ur</i>	<i>-ur</i>

Table 1: The distribution of gen.sg and nom.pl forms of monosyllabic feminine nouns in Icelandic.

The affixes in **Table 1** are “competitors” in the sense that they realize exactly the same morphosyntactic properties and are indistinguishable either phonologically or semantically.

Carstairs-McCarthy argues that the competing affixes obey the PC on the assumption that inflection class membership forms part of the meaning of an affix. On this approach, the suffix *-ir* would not only have the meaning “nominative plural” but “nominative plural, class A”; the suffix *-ar* would mean not just “nominative plural” but plural, Class B. Likewise, the suffix *-ur* would have the meaning “nominative plural, Class C or Class D”; and so on. Thus, competing affixes might obey the PC, in as much as they contrast with respect to the inflection classes with which they are associated.

For psychological plausibility, any theory of morphological acquisition must take the distributional properties of morphology and the developmental patterns and trajectories in child language. Corpus studies of child-directed language have revealed a systematic pattern of data sparsity: The statistical properties of morphology are quite similar to the statistical properties of words, following Zipf’s (1949) law which states that the frequency of a word is approximately inversely proportional to its rank. As a result, relatively few words are used very frequently, while most words occur infrequently and many occur only once, even in large samples of texts. A parallel pattern is visible across inflectional categories; some appear with almost every lemma, but more appear with only a few lemmas. For instance, in a corpus study of Spanish verbal morphology, Lignos and Yang (2016) found that the most frequent inflectional category (third-person singular present indicative) appeared 37,573 times, while two inflectional categories appeared only once each (the first- and second-person imperfect subjunctive) in a 985,262-token corpus of Spanish child-directed speech (MacWhinney 2000). On average, a verb appeared in approximately one of every thirteen inflectional categories observed in the corpus. Thus, a particular combination of lemma and inflectional category is far more likely to be missing than observed (see also Chan 2008 for a formalization of data sparsity). As a consequence, it is unrealistic to expect the full paradigm of any particular stem to be available to the child learner.

In spite of data sparsity, children acquire morphological patterns early: Cross-linguistic studies on vocabulary development have shown that productive inflectional morphology is largely in place around the age of three, when children's vocabulary sizes encompass, on average, only around 1000 words or even less (Hart & Risley 1995; 2003; Szagun et al. 2006). Since, children are not presented with nouns in fully inflected paradigms in acquisition, they need to form generalizations based on the inflectional forms and categories that they encounter in the input. The question is how children are able to discover the relations between individual forms and categories in order to construct the patterns instantiated by inflectional paradigms based on the input data.

Several theoretical approaches have granted privileged status to certain forms within the inflectional paradigm. For instance, Classic Word and Paradigm models assume that each lexeme is represented by a basic, unmodified leading form or principal part from which other forms within the paradigm can be predicted (e.g. Blevins 2004; Matthews 1991; Stump & Finkel 2009). Such forms have also been referred to as base forms (Albright 2002). From a learning perspective, these approaches predict that certain privileged forms guide children's inferences about inflectional morphology in acquisition. Correspondingly, these forms are predicted to be the catalysts of diachronic change. As a result, changes to leading forms that result in wholesale inflection shifts, as has been attested in the history of Germanic (Lahiri & Drescher 1983), are to be expected.

The challenge consists of demarcating „the leaders“ from their „followers“. Leading forms cannot always be identified by a priori definitions of morphosyntactic markedness. For instance, the nominative singular form has standardly been taken to be the citation form (i.e. leading or base form) in Latin noun inflection. However, the well documented *honor* change resulted in the unexpected spread of rhotacism from oblique forms to nominative singular forms in Latin (see e.g. Albright 2004 for an overview and analysis). The change has raised many questions since leading forms have generally been expected to determine the direction of analogical change. It seems to suggest that the status of leading forms within inflectional paradigms is not carved in stone. Thus, different inflectional forms may be able to exert an influence over others under certain conditions. The challenge consists of determining what these conditions are.

2.2. Gender and inflection

The relation between gender and other inflectional forms is a well-known case study of the nature of the interdependencies between linguistic categories (Berg 2019; Corbett 1991; Kürschner & Nübling 2011; Spencer 2002). In spite of their interaction, gender has conventionally not been regarded as an inflectional category. For instance, gender does not induce sets of forms from a single lexeme. In other words, nouns do not form “gender pairs” in the same way that nouns form singular-plural pairs. Rather, gender is an inherent property of the noun (Spencer 2002: 279–

280). Moreover, unlike gender, inflection does not participate in agreement relations (Alexiadou 2004; Hockett 1958). Thus, nouns of the same gender trigger the same agreement, irrespective of inflection. For example, masculine nouns in Icelandic trigger the same agreement morpheme (*-ur*) even if they belong to different inflection classes, as shown in (1):

- (1) a. Falleg-**ur** feldu-**r**.
 Beautiful.M.NOM.SG fur.M.NOM.SG
 ‘Beautiful fur.’
- b. Falleg-**ur** jakk-**i**
 beautiful.M.NOM.SG jacket.M.NOM.SG
 ‘A beautiful jacket.’
- c. Falleg-**ur** stóll-**∅**
 beautiful.M.NOM.SG chair.M.NOM.SG
 ‘A beautiful chair.’

This fact has motivated a theory of grammar in which gender and inflection are linked to different modules; syntax and phonology, respectively (Alexiadou & Müller 2008). In addition, this fact has distributional consequences, since it means that there is not necessarily a one-to-one mapping between gender and inflection classes, although there may be some interaction between these properties. The main point of contention has been the nature of the dependency relation between the two categories: Does gender predict inflection or vice versa? There is evidence from German that gender is predictive of inflection, rather than vice versa, in acquisition: Studies on the acquisition of German nominal inflection have shown that children master productive gender assignment rules by the age of three, whereas they have not mastered noun pluralization by the age of six (e.g. Hahn & Nakisa 2000; Kauschke et al. 2011). Diachronically, plural forms in German have also undergone change in the direction of predictability according to gender, suggesting that the latter is the conditioning factor (Wurzel 1998).

Proponents of inflection-predictive approaches have argued that inflection carries more information than gender alone. Since there are typically more inflection classes than genders, it should be “simpler” to predict gender on the basis of inflection rather than vice versa (Spencer 2002: 36–37). In a similar spirit, Corbett (1991: 49) has argued, on the basis of German and Russian, that gender should be inferred on the basis of inflection class, given that nominative singular forms can correlate with more than one gender. For instance, nouns that end in a soft palatalized consonant in the nominative singular in Russian can be either masculine (e.g. *denj* ‘day’) or feminine (e.g. *kost* ‘bone’) (see Nessel 2003 for a discussion). However, these nouns belong to different inflection classes which means that their oblique forms can serve to disambiguate between genders. On the other hand, given the sparsity of the input data, it seems implausible that children encounter these disambiguating forms in acquisition to learn gender assignment.

A compromise view has been proposed by Enger (2004), based on evidence from Norwegian, that inflection may predict gender for some nouns that are more frequent in the plural than in the singular. Similarly, Doleschal (2000: 125) has argued against a universal preference in the interdependence between gender and inflection class. She argues, based on evidence from Russian, that even in one and the same language, mappings may occur in both directions, although typically one direction will be systematically preferred over the other. However, what determines the directionality in each case has hitherto been unclear.

3. Gender and plural formation in Icelandic

3.1 Gender in Icelandic: Patterns and their acquisition

Icelandic has three grammatical genders: Masculine, feminine and neuter. The Icelandic gender system is typologically classified as formal meaning that formal, rather than semantic information is predictive of gender assignment (Corbett 2013). For example, *hetja* ('hero.F') is formally a feminine noun that can refer to a person of any gender. The three genders are roughly equally frequent in the Tagged Icelandic Corpus (Helgadóttir et al. 2012). Gender distinctions are attested on nouns on the definite article, which most often is a suffix, adjectives, numerals, the verbal past participle and pronouns.

There are correspondences between gender and nominative singular suffixes of nouns in Icelandic, as **Table 2** demonstrates:

NOM.SG.	Masculine	Feminine	Neuter
– <i>r</i>	Bátu- <i>r</i> ('a boat')	Brúðu- <i>r</i> ('a bride')	NA
– <i>i</i>	Penn- <i>i</i> ('a pen')	NA	NA
– <i>a</i>	Herr- <i>a</i> ('Sir')	Kann- <i>a</i> ('a mug')	NA
–∅	Guð-∅ ('God')	Hlíð-∅ ('a hill')	Stríð-∅ ('War')

Table 2: Correspondences between gender and nom.sg. suffixes in Icelandic.

The correspondences in **Table 2** show that there is not necessarily a one-to-one mapping between gender and nominative singular suffix. However, there are correlations: Nouns that take either suffix –*r*¹ or –*i* tend to be masculine. Nouns that take the suffix –*a* tend to be feminine. There are various exceptions to these correlations. For instance, several common female names in Icelandic, including *Sigríður*, take the suffix –*r*. The absence of an overt nominative singular suffix

¹ Most nouns in this class end in –*ur*. The /u/ is assumed to reflect epenthesis, a purely phonological process, independent of gender assignment, which is triggered automatically under suffixation (consult e.g. Thráinsson, 2017 for an overview and discussion).

is indicated by $-\emptyset$. These nouns can belong to any of the three genders. There is no phonological property specific to any of the genders within this class; the stem-final segment can consist of any phonotactically licit consonant in Icelandic (see also a discussion in Björnsdóttir 2021).

The question is how children are able to tease apart generalizations from idiosyncrasies in Icelandic gender assignment, in light of the above discussion. The very same question has been at the heart of research on the acquisition of grammatical gender research cross-linguistically, often with conflicting results and conclusions. Children have been shown to follow different learning trajectories depending on the nature of the target gender system (see, among many, Boloh & Ibernnon 2010; Karmiloff-Smith 1979; Mills 1986; Rodina & Westergaard 2012; Thomas & Mueller Gathercole 2007). Transparency, the strength of a formal cue to gender assignment, has been argued to be predictive of children's behavior in gender acquisition (Slobin 1977). The acquisition of transparent gender systems, like, for example, Spanish (Pérez-Pereira 1991), is characterized by early attainment and errors of over-generalization. By contrast, the acquisition of opaque gender systems, like, for example Norwegian (Rodina & Westergaard 2015), is characterized by protracted development and lexical conservatism. However, the unresolved issue consists of explaining how the child learner discovers whether the target gender system is transparent – or not. How do children evaluate the strength of a formal cue to gender assignment? In other words, under what conditions do children converge on a systematic (i.e. “transparent”) generalization – and when do they not?

To address these issues, Björnsdóttir (2021) conducted a series of corpus analyses in order to predict productivity – and absence thereof – in the correspondences between nominative singular suffixes and gender assignment in Icelandic (see **Table 2**), using a learning model (Yang 2005; 2016). The nominative singular suffixes $-r$ and $-i$ were predicted to be productive of masculine. The nominative singular suffix $-a$ was predicted to be productive of feminine. In the absence of these suffixes ($-\emptyset$), no gender was predicted to be productive. In other words, in the absence of a productive nominative singular suffix, speakers of Icelandic were predicted to rote-memorize gender assignment. These predictions were put to the test on both adults ($N = 18$) and children ($N = 26$, ages 2;6–6;3 years) in an elicited production task with two conditions: Productive and unproductive (Björnsdóttir 2021). In the productive condition, participants were exposed to a novel noun with a nominative singular suffix ($-r$, $-i$, $-a$) hypothesized to be productive under Yang's learning model. In the unproductive condition, they were exposed to a novel noun (monosyllabic or disyllabic) that did not bear such a suffix ($-\emptyset$).

The results suggest that both children and adults draw a categorical distinction between productive and unproductive suffixes in Icelandic: In the productive condition, they made categorical suffix-based choices of gender (masculine for $-r$ and $-i$, feminine for $-a$). By contrast, they made unsystematic choices of gender in the unproductive condition, with neuter constituting less than half of both adult and child responses. There was no effect of age on children's neuter

assignment in the unproductive condition ($r = .09$). Therefore, neither adults nor children resorted to neuter as a default in the absence of a productive nominative singular suffix, even if neuter has standardly been assumed to be the default gender in Icelandic (e.g. Steinmetz 1985), since it is attested in contexts where agreement is assumed to be inert, such as on clausal and oblique subjects. As a result, children seem to learn gender assignment in Icelandic in the absence of a productive gender default.

The findings further suggest that children can learn gender assignment in both a rule-based manner and on an item-by-item basis, as evidenced by the Icelandic gender system, which is simultaneously transparent and opaque. Lexical conservatism has often been invoked to argue against rule-based learning and in favor of gradient representations in acquisition (see, among many, Thomas & Mueller Gathercole 2007). Crucially, on this approach, the absence of productivity does not constitute evidence against rule-based learning. Rather it is a direct consequence of a learning process guided by a search for productivity that fails to succeed and results in rote memorization. The same method can be applied to any gender system to predict the conditions for productivity (“transparency”) – as well as the absence of productivity (“opacity”) (see Björnsdóttir 2021 for an analysis of the Spanish gender system).

3.2 Noun pluralization in Icelandic

Marking plurality in Icelandic involves a morphological selection process between five plural allomorphs: *-ar*, *-ir*, *-ur*, $-\emptyset$ and *-u*. Standard descriptions of Icelandic noun inflection state that grammatical gender is encoded both in the singular and the plural (see e.g. Kvaran 2005: 201). Thus, there are correspondences between gender and the choice of plural suffix. Since there are correlations between nominative singular forms and gender assignment there are also correspondences between nominative singular and nominative plural suffixes, although there is considerable syncretism. The correspondences between gender, nominative singular suffixes and nominative plural suffixes are stated in **Table 3**.

	Masculine				Feminine				Neuter			
NOM.SG suffix	<i>-r</i>	<i>-i</i>	<i>-a</i>	$-\emptyset$	<i>-r</i>	<i>-i</i>	<i>-a</i>	$-\emptyset$	<i>-r</i>	<i>-i</i>	<i>-a</i>	$-\emptyset$
NOM.PL suffix	<i>-ar</i>	<i>-ar</i>	<i>-ar</i>	<i>-ar</i>		NA		<i>-ar</i>	NA	NA	NA	
	<i>-ir</i>	<i>-ir</i>			<i>-ir</i>			<i>-ir</i>				
	$-\emptyset$							$-\emptyset$				$-\emptyset$
		<i>-ur</i>					<i>-ur</i>	<i>-ur</i>				
												<i>-u</i>

Table 3: Correspondences between gender, nom.sg. suffix and choice of plural suffix.

Table 4 shows how plural suffixes are mapped on to real nouns by gender:

NOM.PL	Masculine	Feminine	Neuter
– <i>ar</i>	hest-ar (‘horses’)	skál-ar (‘bowls’)	NA
– <i>ir</i>	dal-ir (‘valleys’)	borg-ir (‘cities’)	NA
– <i>ur</i>	bænd-ur (‘farmers’)	kon-ur (‘women’)	NA
–∅	menn-∅ (‘men’)	mýs-∅ (‘mice’)	torg-∅ (‘squares’)
– <i>u</i>	NA	NA	aug-u (‘eyes’)

Table 4: Gender and plural formation in Icelandic.

The morphological selection process is confined to nominative plural forms, meaning that most nouns, irrespective of gender or inflection class, share the same suffix in oblique cases in the plural, albeit with exceptions. Masculine nouns undergo a subtraction process in the accusative plural. For example, the nominative plural form of *hest-ar* (‘horses’) is *hest-a* in the accusative plural. All nouns take the same suffixes in the dative and genitive plural, irrespective of gender or inflection class; dative plural takes *-um* and genitive plural *-a*. Plural nouns in Icelandic are affected by systematic morphophonological processes, such as [ɣ]-umlaut (e.g. Thráinsson 2017), that are not specific to plural formation. These processes are triggered automatically under suffixation, independently of plural formation. For instance, although all strong neuter nouns are without a suffix, they may undergo distinct stem alternations within their respective paradigms, like *lönd-∅* (country-nom.pl, derived from *land-nom.sg*) and *héruð-∅* (district-NOM.PL, derived from *hérað-NOM.SG*) (consult Kvaran 2005: 191–195 for an overview and discussion).

Grammatical gender narrows down the range of options with respect to plural formation. For example, neuter nouns do not pluralize productively by suffixation. Still, there is considerable overlap in the plural marking of masculine and feminine nouns. Most descriptive accounts state a correspondence between masculine assignment and *–ar*. For example, borrowed masculine nouns typically select *–ar* (Rögvaldsson 2013: 171). Synchronically, there is a tendency for some masculine nouns that select *–ir* to drift over to *–ar*, such as *Japan-ir/Japan-ar* (Japanese.M.PL; ‘Japanese’). Furthermore, children have been found to overgeneralize *–ar* when pluralizing masculine nouns (Gíslason et al. 1986). These facts seem to suggest a productive correspondence between masculine assignment and *–ar*, in spite of syncretism with feminine.

Feminine nouns that take the nominative singular suffix *–a* invariantly pluralize with *–ur*. Otherwise, they take either *–ar* or *–ir*, but rarely *–ur*. Therefore, *–ur* seems productive only in the context of the feminine nominative singular *–a* suffix. Many monosyllabic feminine nouns show free variation between *–ar* and *–ir*, like *lest* (‘train’) and *hurð* (‘door’), with both inter- and intra-speaker variation (Jónsdóttir 1988–1989). Diachronically, feminines have also shifted between

the two plural suffixes. For example, both *þjóð* ('nation') and *vél* ('machine') could take either suffix at an earlier diachronic stage. The former can only take *-ir* in modern Icelandic, while the latter invariantly selects *-ar* (Iversen 1972: 52–53). In spite of free variation, many accounts claim that the default plural suffix for feminine nouns is *-ir* (e.g. Bjorvand 1972; Wurzel 1987).

While plural forms are standardly assumed to be derived from singular base forms, there are some nouns that have no possible singular forms. Many pluralia tantum nouns in Icelandic are neuter. A few examples are given in (2):

- (2) a. *Jól-in* koma./ **Jól-ið* kemur.
 x-mas.N.PL come.PL /x-mas.N.SG come.SG
 'X-mas is coming.'
- b. *Viðskipt-in* ganga vel./ **Viðskipt-ið* gengur vel.
 business.N.PL go.PL well/ business.N.SG go.SG well
 'Business is going well.'
- c. *Verðlaun-in* eru vegleg- \emptyset ./ **Verðlaun-ið* er vegleg-t.
 prize.N.PL is.PL grand.N.PL/prize.N.SG is.SG grand.N.SG
 'The prize is grand.'
- d. *Vonbrigð-in* eru mikil- \emptyset ./ **Vonbrigð-ið* er mik-ið.
 disappointment.N.PL is.PL big.N.PL/ disappointment.N.SG is.SG big.N.SG
 'It's a big disappointment.'

There are no semantic reasons for this ineffability; the nouns in (2) can be classified into several semantic categories. Rather, it seems to reflect the absence of a productive singular form. This fact is intriguing in light of the above discussion regarding the nature of interdependencies between linguistic categories: Why does neuter have a productive pattern in the plural – but not in the singular?

4. The relation between gender and plural formation: Predictions for learning

4.1 The Tolerance Principle

Yang (2005; 2016) has proposed a quantitative measure, the Tolerance Principle, to distinguish between productive and unproductive processes in language. On this approach, the notion of productivity is understood as the ability of a linguistic pattern to apply to an open-ended set of lexical items (for other uses and interpretations, consult Bauer 2001). The principle is stated in (3):

(3) **The Tolerance Principle**

If R is a productive rule applicable to N candidates, then the following relation holds between N and e , the number of exceptions that could but do not follow R : $e \leq \theta_N$
 where $\theta_N = N/\ln N$.

The Tolerance Principle makes use of the Elsewhere Condition (Kiparsky 1973) which states that when a more specific form (or rule) is available, it is preferred over a more general one. For example, the irregular past tense form *went* would be preferred over a regular past tense form **goed* in most theories of morphology (e.g. Anderson 1992; Halle & Marantz 2008). The Elsewhere Condition is implemented by the Tolerance Principle as a serial search procedure which is empirically motivated by research on language processing (see Yang 2016: 49–60). To illustrate this serial procedure, one can think of past tense acquisition in English. The child is faced with verbs that adhere to the regular pattern, ‘add *-ed*’ and verbs that do not. The Tolerance Principle assumes that, in order to be maximally efficient in forming the past tense of verbs in English, the child is faced with two options: 1) Store all past tense verb forms individually 2) Form a productive rule. In the first case scenario, every item is stored in a list ranked by frequency. This means that the learner must search the list every time there is an occasion to express the past tense of a verb. In the second case scenario, only the exceptions are stored in a frequency-ranked list. The list of exceptions must be searched first before the productive rule can be applied.

The model hypothesizes that a general rule will only be formed if it is computationally more efficient than storing lexical forms. Computational efficiency is computed by comparing the time complexity required for forming a rule with the time complexity required for accessing individual lexical items. The Tolerance Principle quantifies the precise conditions for productive rule formation. It is computationally more efficient to form a productive rule only when the number of exceptions is less than the number of items divided by the natural log of the number of items. The principle is a threshold function that predicts a categorical division between productive and unproductive processes in language. On this approach, the difference between the two is a direct consequence of children’s search for productive patterns in learning.

The Tolerance Principle operates on type counts. Therefore, productivity in grammar learning on this approach is connected to the number of types over which linguistic patterns are expressed, rather than the number of tokens. This does not mean that token frequency is entirely irrelevant to the Tolerance Principle; the time complexities from which the Tolerance Principle is derived makes use of the distribution of word frequencies, as mandated by Zipf’s (1949) law. However, ultimately, the learner only needs to know the number of types and how many of those are exceptions.

While the Tolerance Principle can predict the precise conditions for productive rule formation, it does not follow that children only learn language in a rule-based manner. Children’s lexical conservatism in acquisition has often been used as evidence against rule-based learning (Tomasello 2003; Dabrowska 2005). The Tolerance Principle can also predict the absence of productivity and, as a result, item-based learning (see Yang 2016: 152–156 on defective inflection in Russian and Polish). Crucially, however, absence of productivity does not constitute evidence

against rule-based learning. Rather, it is the direct consequence of a learning process guided by a search for productivity that fails to succeed and results in rote memorization.

Morphological classes have structural properties such as gender, case and number. These properties produce subclasses of words. On this approach, these subclasses are a consequence of learning. The learner searches for productivity within subclasses if no productive rule initially emerges over a full set of items (e.g. all nouns). Thus, the learner's bias to maximize productivity motivates them to apply the Tolerance Principle recursively over a subset of items. In other words, the absence of a global default in an inflectional system probes the learner to search for sub-regularities.

4.2 Corpus analyses

The top 1000² most frequent nominative plural noun types in the Tagged Icelandic Corpus (Helgadóttir et al. 2012) were subjected to an analysis using the Tolerance Principle, with both grammatical gender and phonological properties as conditioning factors. The purpose of the study was to predict productivity – and absence thereof – between these factors and choice of plural suffix. The Tagged Icelandic Corpus (MÍM) is a morpho-syntactically tagged corpus of Icelandic consisting of about 25 million tokens of contemporary Icelandic texts collected from varied sources during the years 2006–2010. The analysis is provided. in **Table 5**:

The analysis incorporated gender and phonological properties as conditioning factors by adding all noun types by gender and calculating an exception threshold (see (3) in section 4.1) based on the sum of noun types within each gender. The total number of masculine types in the corpus is $352 + 37 + 11 + 8 = 408$. The number of exceptions that a generalization involving masculine nouns is predicted to tolerate is $408/\ln 408 = 67$. On this analysis, there is a productive correlation between masculine and *-ar* since the number of masculine nouns that do not select *-ar* ($37 + 11 + 8 = 56$) is below the exception threshold (67).

The total number of feminine noun types bearing the nominative singular suffix *-a* is 139. This number is used to calculate the predicted exception threshold ($139/\ln 139 = 28$). There are no exceptions to this pattern, hence a productive correlation between nominative singular *-a* and nominative plural *-ur* is trivially confirmed.

² The top 1000 most frequent noun types were extracted in light of research on corpora comparability which has shown that the main difference between adult literary corpora and child-directed speech involves low frequency lexical items. Kodner (2019) found that once adult literary corpora had been trimmed by frequency, they had statistically similar type counts to child-directed speech corpora in spite of lexical differences. One implication of these findings is that children's grammar learning may be based on high frequency lexical items, rather than adult-size lexicons. The cut-off point at 1000 nouns was the lowest sample number containing all possible plural patterns.

The number of feminine noun types that bear no overt suffix ($-\emptyset$) is $(59 + 137 + 3 + 1 = 200)$. This number yields an exception threshold of $200/\ln 200 = 38$. The number of feminine nouns within this class that select $-ir$ is 137. Since the number of nouns within this class that take $-ar$ is 59, which exceeds the exception threshold (38), no productive correlation is predicted between feminine and $-ir$. Likewise, the number of nouns that select $-ir$ is too great for a productive correlation between feminine and $-ar$ to hold ($137 > 38$). Therefore, the feature [+feminine] is predicted to yield no productive generalization (hence the free variation between plural suffixes $-ir$ and $-ar$ for strong monosyllabic feminine nouns). As a consequence, the learner has to further subdivide feminine nouns in the search for productivity. This search is predicted to result in a productive generalization between feminine nouns that take the nominative singular suffix [a] and the plural suffix $-ur$. Finally, a productive correspondence between neuter assignment and $-\emptyset$ was predicted since the number of neuter nouns that select the suffix $-u$ is below the exception threshold ($46 > 7$).

Plural suffix	M	F		N	Productive?			
		$-a$	$-\emptyset$		M	F	N	
$-ar$	352	$-a$	$-\emptyset$	0	Yes ($67 > 56$)	$-a$	$-\emptyset$	NA
		0	59			NA	No ($38 < 141$)	
$-ir$	37	$-a$	$-\emptyset$	0	No ($67 < 371$)	$-a$	$-\emptyset$	NA
		0	137			NA	No ($38 < 63$)	
$-ur$	11	$-a$	$-\emptyset$	0	No ($67 < 381$)	$-a$	$-\emptyset$	NA
		139	3			Yes ($28 > 0$)	No ($38 < 196$)	
$-\emptyset$	8	$-a$	$-\emptyset$	246	No ($67 < 400$)	$-a$	$-\emptyset$	Yes ($46 > 7$)
		0	1			NA	No ($38 < 199$)	
$-u$	0	$-a$	$-\emptyset$	7	NA	$-a$	$-\emptyset$	No ($46 < 246$)
		0	0			NA	NA	
Total	408	$-a$	$-\emptyset$	253				
		139	200					
θ_N	67	$-a$	$-\emptyset$	46				
		28	38					

Table 5: Quantifying correspondences between gender and plural suffixes in Icelandic.

Based on this analysis, three productive rules of plural formation in Icelandic can be identified and stated in (4):

- (4) a. PL \rightarrow *-ar* / [+masculine]
 b. PL \rightarrow *-ur* / [nom.sg] [a] _ #
 c. PL \rightarrow \emptyset / [+neuter]

Other patterns are listed in the lexicon and learned by rote. Recall that the Tolerance Principle predicted there to be no productive pattern for neuter in the singular. As a result, neuter assignment was predicted to be rote-memorized. While a speaker may productively associate the plural suffix \emptyset with neuter, they would have to have memorized that a singular noun is neuter in order to pluralize it with \emptyset . Therefore, in the absence of a productive nominative singular form on a novel noun, speakers are predicted to be at a loss with both gender assignment and plural formation in Icelandic. In other words, uncertainty in gender assignment is predicted to coincide with uncertainty in plural formation.

A second study tested the productivity of the same mappings, except with the causal relation reversed. Plural suffixes were used as conditioning factors in a corpus analysis using the Tolerance Principle on the top 1000 most frequent noun types in the Tagged Icelandic Corpus. The suffix *-u* was excluded from this study due to its low frequency. The purpose of the study was to generate predictions for children's learning: Given knowledge of a plural form, can children infer the noun's gender? The analysis is provided in **Table 6**:

Gender	<i>-ar</i>		<i>-ir</i>		<i>-ur</i>		\emptyset		Productive?			
	<i>-a</i>	\emptyset	<i>-a</i>	\emptyset	<i>-a</i>	\emptyset	<i>-a</i>	\emptyset	<i>-ar</i>	<i>-ir</i>	<i>-ur</i>	\emptyset
M	352		37		11		8		Yes	No	No	No
F	<i>-a</i>	\emptyset	<i>-a</i>	\emptyset	<i>-a</i>	\emptyset	<i>-a</i>	\emptyset	\emptyset	\emptyset	<i>-a</i>	\emptyset
	0	59	0	137	139	3	0	1	No	No	Yes	No
N	0		0		0		246		NA	NA	NA	Yes
Total	411		174		153		255					
q_N	68		34		30		46					

Table 6: Quantifying correspondences between plural suffixes and gender in Icelandic.

The plural suffix *-ar* was predicted to be productive of masculine since the number of non-masculine nouns (59) that select this suffix did not exceed the exception threshold (68). By contrast, the plural suffix *-ir* was predicted to have no productive gender correlate: The number of feminine nouns that select *-ir* (137) was too high for a productive correlation with masculine given an exception threshold of 34 nouns. Likewise, the number of masculine nouns

(37) exceeded the threshold and, thus, prevents a productive correlation with feminine. The plural suffix *-ur* was predicted to correlate productively with the nominative singular suffix *-a* since the exceptions to this pattern ($11 + 3 = 14$) were below the threshold (30). Finally, $-\emptyset$ was predicted to correlate productively with neuter ($46 > 9$).

On this approach, the acquisition of noun inflection in Icelandic may be viewed as inductive process guided by the search for productive interdependencies between inflectional forms. **Figure 1** illustrates how this works for gender and plural formation in Icelandic:

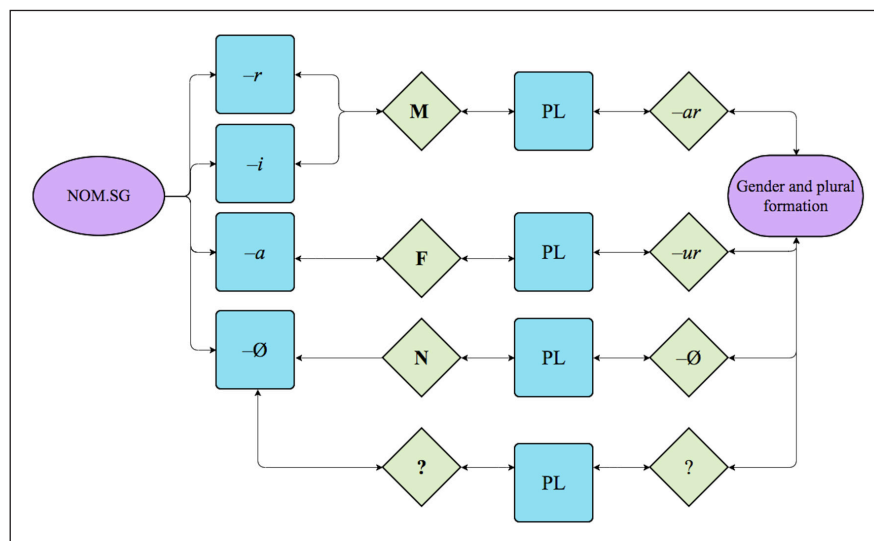

Figure 1: Flow chart of the interdependencies between forms in gender and plural formation in Icelandic.

The flow chart can be viewed as a decision tree illustrating the learning process: It demonstrates how productive nominative singular forms facilitate the induction of both gender and plural forms in Icelandic. The privileged role of nominative singular forms is to be expected given that young children will have encountered most nouns in the nominative singular (see discussion in section 2.1). Crucially, however, not all nominative singular forms will lead to a productive generalization: The absence of a productive nominative singular form is predicted to result in ineffability in both gender and plural formation in Icelandic. There is no productive nominative singular form for neuter nouns. However, given knowledge of a noun's neuter assignment, via rote memorization, a speaker is predicted to be able to pluralize neuter nouns productively. Conversely, the plural form $-\emptyset$ is predicted to facilitate neuter assignment. In other words, the absence of a productive nominative singular form blocks the flow of information between the processes, resulting in a gap within the system. This gap may account for why numerous neuter nouns in Icelandic have a defective singular paradigm.

5. Experiment 1: Elicitation of grammatical gender and nominative plural forms based on exposure to nominative singular forms

5.1 Materials

The test items consisted of 24 novel nouns, 12 for each condition. In the productive condition, the novel noun had a productive nominative singular suffix (*-r* or *-i* for masculine, *-a* for feminine, as shown in **Table 3** in section 3.2). In the unproductive condition, the novel noun did not bear such a suffix. The experiment followed the same logic as the experimental study in Björnsdóttir 2021, discussed in section 3.1. **Table 7** shows the test items sorted by condition:

Productive			Unproductive	
<i>-r</i>	<i>-i</i>	<i>-a</i>	–∅ Monosyllabic	–∅ Disyllabic
Lerfur	Ruli	Bukla	Súf	Kútes
Tirgur	Krandi	Darga	Turk	Ratef
Mekur	Lurpi	Mæka	Mæf	Farem
Rullur	Tauli	Fóma	Lirg	Múkaf
			Kurk	Sakem
			Glæf	Lútis

Table 7: Test items per condition.

The novel nouns were paired with novel objects in the form of flying toasters (Glitch 2012). Prior to the test, the participant was introduced to the novel object with a picture, as **Figure 2** demonstrates:



Figure 2: A novel object prior to test.

Simultaneously, the participant was exposed to an audio stimulus which repeated the novel noun twice in syntactic contexts where the nominative singular is obligatory, as shown in (5):

- (5) a. Þetta er **lerfur**.
 this is lerfur.M.NOM.SG.
 ‘This is a lerfur.’
- b. Vá! **Lerfur!**
 wow lerfur.M.NOM.SG.
 ‘Wow! A lerfur!’

The test items were organized into six trials, each consisting of two test items from each condition, presented in a randomized order.

The experiment was embedded in interactive animated video game that was designed using Animaker, an online animation software. Participants were asked to engage with the game verbally to affect the course of events in the storyline and move on to the next test item. Each game was 13 minutes in duration, which included a training session on three real nouns, one for each gender.

5.2 Procedure

Children and adults were tested individually in a quiet location at a day care center or at the University of Iceland. The objective of the task was to locate flying toasters that had gone missing from a scientific laboratory. In the test scene, two-to-four flying toasters either emerged from the background or attempted to hide from view. In addition to locating the novel objects, the participant was asked to provide the correct number of flying toasters observed in each test scene. **Figure 3** shows an example of a test scene after the novel objects had come to view.



Figure 3: Example test scene.

After having located and identified the number of flying objects, the participant was asked to communicate their knowledge to the story protagonist. The test sentence elicited gender agreement on the numeral in addition to plural marking, as exemplified by (6).

- (6) a. Þarna eru **tveir** **lerfar**.
 there are two.M.SG lerfur.M.PL
 ‘There are two lerfurs.’
- b. Þarna eru **tvær** **buklur**.
 there are two.F.SG bukla.F.PL
 ‘There are two buklas.’
- c. Þarna eru **tvö** **súf**.
 there are two.N.SG súf.N.PL
 ‘There are two súfs.’

Once the participant had produced the test sentence, the video proceeded on to the presentation of the next test item. Prior to the test, the participant received training with real nouns of each gender. Their responses were audio recorded and written down by the experimenter.

5.3 Analysis

The data were subjected to inferential statistical analyses to test for significance relations. First, a significance test was conducted with nominative singular forms as an independent variable and plural suffix as a dependent variable. Second, a significance test was conducted with grammatical gender as an independent variable and plural suffix as a dependent variable. Stimulus repetition was coded as a null suffix (–Ø). The analyses are based on by-participant proportion of target responses. There were no missing data for either child or adult participants.

5.4 Participants

27 children ($M = 4;0$ years, $SD = 10$ months, age range = 2;4–5;6 years; 15 females, 12 males) and 20 adult controls participated in this study. An additional five children participated, but were excluded from analysis due to failure to understand the task or unwillingness to engage with the game. Children were recruited from a day-care center in suburban Reykjavík, where the study was conducted. Adult participants were recruited at the University of Iceland, Reykjavík. All participants were native speakers of Icelandic with normal hearing and normal to corrected-to-normal vision. No participant reported to have a history of language delay. Participants provided informed consent.

5.5 Predictions

The predictions for experiment 1 are recapitulated in **Table 8**, for convenience:

Nominative singular suffix	Predicted gender	Predicted plural suffix
<i>-r, -i</i>	Masculine	<i>-ar</i>
<i>-a</i>	Feminine	<i>-ur</i>
$-\emptyset$	Indeterminate	Indeterminate

Table 8: Predictions for experiment 1.

The Tolerance Principle models the division line between linguistic rules that may apply to an open-ended set of lexical items and others that are lexically restricted to a finite list. It predicts a significant difference in the response patterns in the two conditions: In the productive condition, participants are predicted to converge on a systematic generalization, while in the unproductive condition they are predicted not to do so.

5.6 Results

The predictions stated in **Table 9** were borne out for both children and adults. **Figures 4–5** visualize the relationship between the choice of nominative singular suffix based on plural suffix in participants' responses:

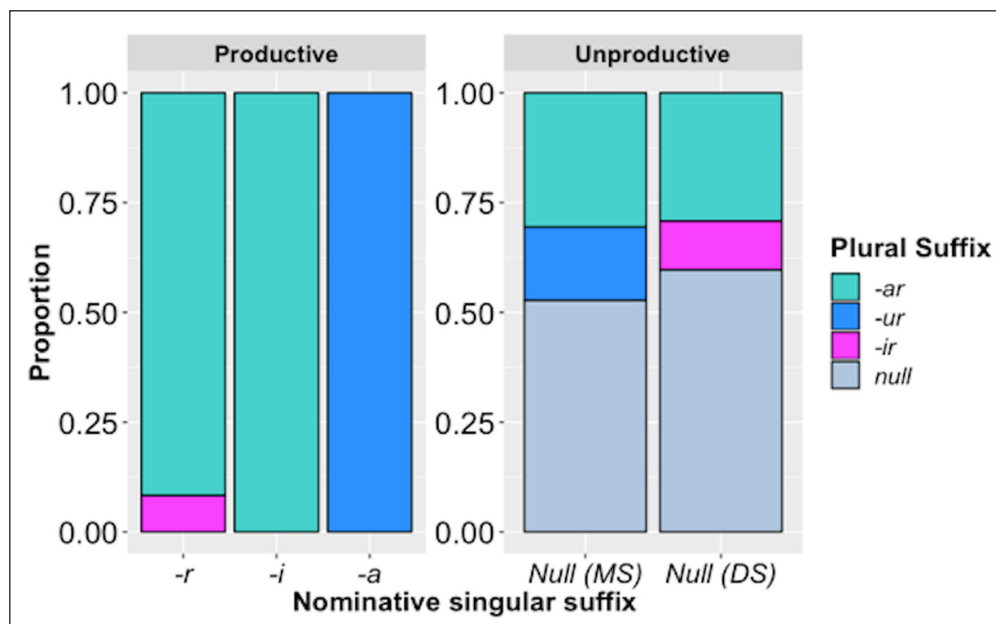

Figure 4: Adults' responses.

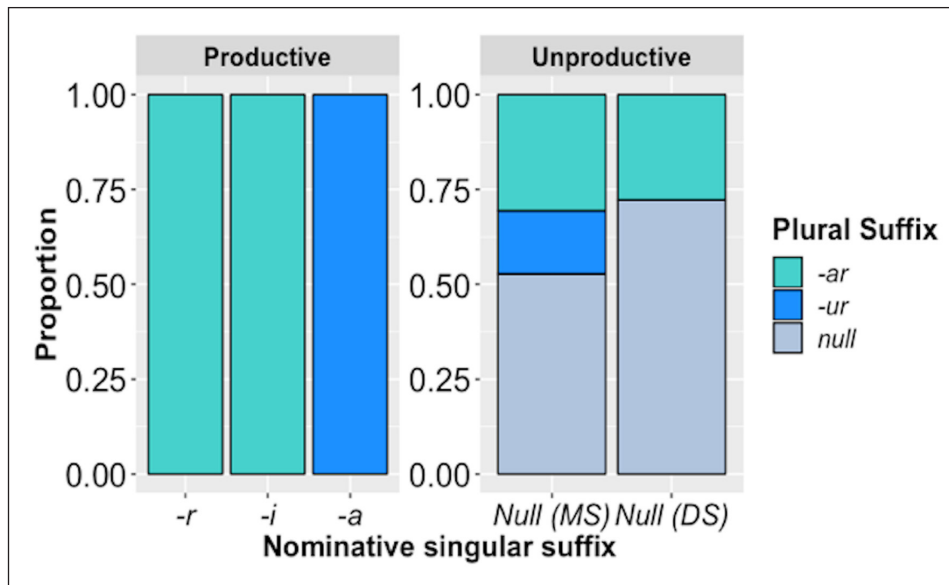

Figure 5: Children's responses.

In the productive condition, both children and adults made a categorical choice of a plural suffix: They chose *-ar* consistently as the plural suffix for novel nouns with the nominative singular suffixes *-r* and *-i*, both of which are productive of masculine (in line with the results of Björnsdóttir 2021). Likewise, they chose *-ur* (100%) as the plural suffix for novel nouns with the nominative singular suffix *-a*. Response patterns in the unproductive condition were characterized by a great deal of both inter- and intra-speaker variation for both children and adults.

For adults, a null suffix (zero response or stimulus repetition) constituted around one half of all responses in the unproductive condition ($M = 0.48$, $SD = 0.31$, $SE = .07$). The second most frequent plural suffix was *-ar* ($M = 0.33$, $SD = 0.27$, $SE = .06$), followed by *-ir* ($M = .08$, $SD = 0.11$, $SE = .06$) and *-ur* ($M = .08$, $SD = 0.1$, $SE = .02$). Over half (12) of the participants never used *-ir*. Adults were equally likely to choose a null suffix for novel monosyllabic (MS) and disyllabic (DS) nouns: $t(22) = 22$, $p < 0.55$.

A null suffix (zero response or stimulus repetition) constituted around one half of children's responses in the unproductive condition as well ($M = 0.52$, $SD = 0.35$, $SE = .069$). One child made a categorical choice of a null suffix. On average, children chose *-ar* 33% of the time ($SD = 0.29$, $SE = .001$). Three children were near-categorical in their choice of *-ar*. No child chose *-ur* consistently ($M = .087$, $SD = 0.12$, $SE = .023$). Children never chose *-ir*. Overall, children were categorical in their choice of a null suffix for disyllabic nouns ($M = 0.73$, $SD = 0.22$, $SE = .04$). Responses distributed at chance between null and other suffixes in the case of monosyllabic nouns ($M = 0.51$, $SD = 0.22$, $SE = .01$).

Figures 6–7 visualize the relationship between gender assignment, as expressed by the numeral, and plural suffix in participants’ responses:

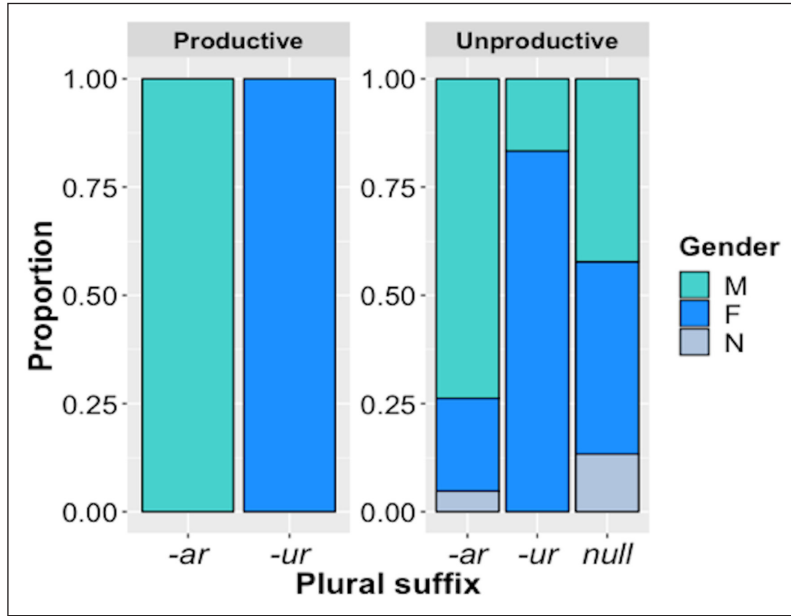

Figure 6: Adults’ responses.

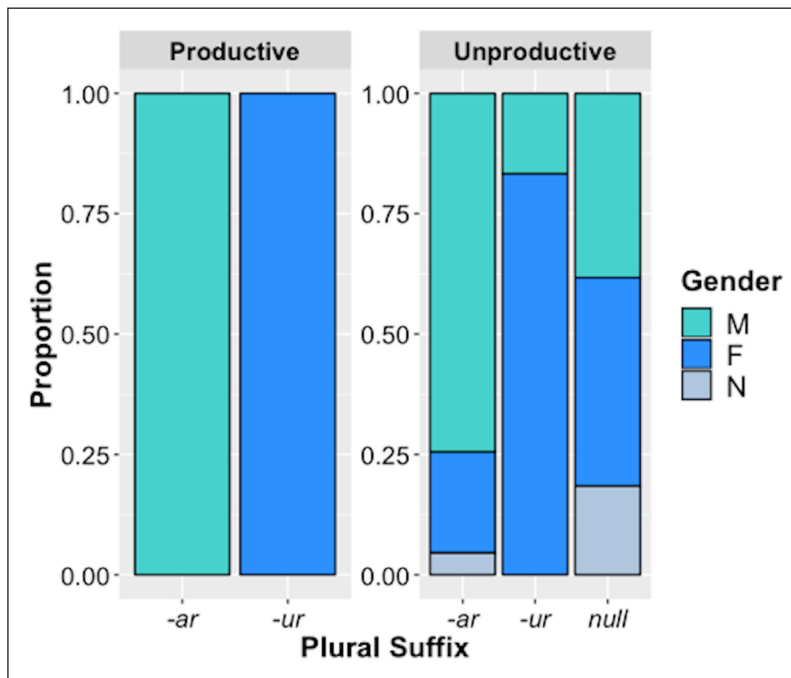

Figure 7: Children’s responses.

The association between gender and choice of plural suffix was significant for adults ($c2(6) = 27.91, p < .01$) and children ($c2(4) = 182.1, p < .01$). In the productive condition, masculine invariably correlated with the choice of *-ar* and feminine with the choice of *-ur*. In the unproductive condition, *-ar* was also categorically associated with masculine and *-ur* with feminine. These correlations were significant in the unproductive condition as well: *-ar* was invariably associated with masculine and *-ur* with feminine in both child and adult responses.

There were some child and adult differences in the unproductive condition: Collectively, adults did not assign gender systematically in the cases they chose a null plural suffix. However, three adults always used masculine agreement conjointly with a null plural suffix and one adult used feminine categorically. Overall, masculine was the most frequently used gender in such cases ($M = 0.53, SD = 0.27, SE = .06$), followed by feminine ($M = 0.27, SD = 0.2, SE = .01$) and neuter ($M = 0.2, SD = 0.18, SE = .009$). Almost one half of adults (eight) never used neuter in the task. For children, masculine was most frequently chosen with a null suffix ($M = 0.6, SD = 0.29, SE = .06$), followed by feminine ($M = 0.32, SD = 0.25, SE = .05$). Neuter was chosen, on average, 8% with a null suffix ($SD = 0.13, SE = .025$).

5.7 Summary and interim discussion

In the experiment, I asked whether the same conditions trigger productive rule formation – and absence thereof – in both gender assignment and plural formation in Icelandic, as predicted by the Tolerance Principle. The predictions were borne out in the task: Both children and adults converged on systematic generalizations in gender and plural formation when exposed to a novel noun with a productive nominative singular suffix in the productive condition. By contrast, there were no systematic patterns of generalizations attested in the unproductive condition for either children or adults. While response patterns were uniform across participants in the productive condition, they were characterized by a great deal of inter- and intra-speaker variation in the unproductive condition. Hence, productivity in gender assignment correlated with productivity in plural formation. There were no age effects in the task; the distinction between productive and unproductive processes in both gender and plural marking in Icelandic seems to be in place by the age of three. Therefore, young children seem able to use productive nominative singular forms to guide their inferences about gender and plural forms of novel nouns. Thus, children's generalizations, which they form on the basis of very modest vocabularies, results in life-long and stable knowledge of grammar.

While a few participants provided categorical responses in the unproductive condition, they did not necessarily converge on a generalization. In a task, whereby participants must provide

an answer in order for the game to move on to the next test item, ineffability will inevitably manifest itself in different ways. Crucially, however, response patterns for both children and adults seemed to reflect the absence of a productive generalization.

There were minimal differences between children and adults in the task. Collectively, both adult and child responses were distributed between null and other forms in plural marking in the unproductive condition. The interpretation of zero responses in experimental settings has been debated (Berko 1958; Köpcke 1998). In the case of Icelandic, a zero response is ambiguous between the choice of a null suffix and stimulus repetition. In the former scenario, the choice may reflect the application of a productive rule, whereas in the latter, it may reflect uncertainty. Zero responses were only attested in the unproductive condition. Children and adults rarely or never pluralized a neuter noun with an overt suffix. However, zero responses were attested with all genders, notably masculine and feminine. Therefore, zero responses seem to reflect uncertainty in both gender and plural formation.

Children never used the plural suffix *-ir* and adults rarely did so either. Neuter constituted less than 10% of children's responses and around a fifth of adults' responses in the unproductive condition. The Tolerance Principle provides a theory of the precise numerical conditions under which children have sufficient evidence to form productive generalizations based on the input. In the foundational study on Icelandic gender assignment (Björnsdóttir 2021), a series of corpus studies were conducted to approximate children's vocabulary sizes at different stages of acquisition. The results suggest that children are able to discover productive generalizations about Icelandic gender assignment based on very modest vocabularies, containing as little as 100 nouns. In other words, children are predicted to be adult-like from early on with respect to gender and inflectional morphology in Icelandic. These results are in line with cross-linguistic findings confirming children's early mastery of inflectional morphology (see e.g. Szagun et al. 2006 for grammatical gender and inflectional morphology in German).

6. Experiment 2: Elicitation of grammatical gender and nominative singular forms based on exposure to nominative plural forms

6.1 Materials

The test items consisted of 24 novel nouns, 12 for each condition. In the productive condition, the novel noun had a nominative plural suffix with a productive gender correlate (*-ar* for masculine, *-ur* for feminine and *-ø* for neuter). In the unproductive condition, the novel noun had a nominative plural suffix with no such productive gender correlate (*-ir*).

Table 9 shows the test items sorted by condition:

Productive			Unproductive	
<i>-ar</i>	<i>-ur</i>	<i>-ø</i>	<i>-ir</i>	
Lerfar	Kurkur	Súf	Lurgir	Fólrir
Lurpar	Buklur	Turk	Ralir	Lerpir
Krandar	Rulur	Glæf	Flúsir	Mæfir
Mekar	Taulur	Lirg	Sergir	Turgir
Dergar	Saulur	Mirg	Mukkir	Túsir
			Tefir	Kúfir
			Fekir	Belir
			Múlrir	Rúfir

Table 9: Test items per condition.

The novel nouns were paired with novel objects in the form of flying toasters (Glitch 2012), just like in Experiment 1. However, this time the novel objects were presented in groups of two to four. Each group contained novel objects of the same specimen. Prior to the test, the participant was introduced to the novel objects with a picture, as **Figure 8** demonstrates.



Figure 8: Novel objects prior to test.

Simultaneously, the participant was exposed to an audio stimulus which repeated the novel noun twice in syntactic contexts where the nominative plural is obligatory, as shown in (7):

- (7) a. Þarna eru **lerfar**.
 these are lerfur.M.NOM.PL.
 ‘Here are lerfs.’
- b. Vá! **Lerfar!**
 wow lerfur.M.NOM.PL.
 ‘Wow! Lerfs!’

The test items were organized into six trials, each consisting of two test items from each condition, presented in a randomized order.

6.2 Procedure

Children and adults were tested individually in a quiet location at a primary school in Reykjavík or at the University of Iceland. In the video, one of the novel objects went missing from the group. The task consisted of locating the missing novel object in the test scene. **Figure 9** provides an example of a test scene once the missing object had been identified.

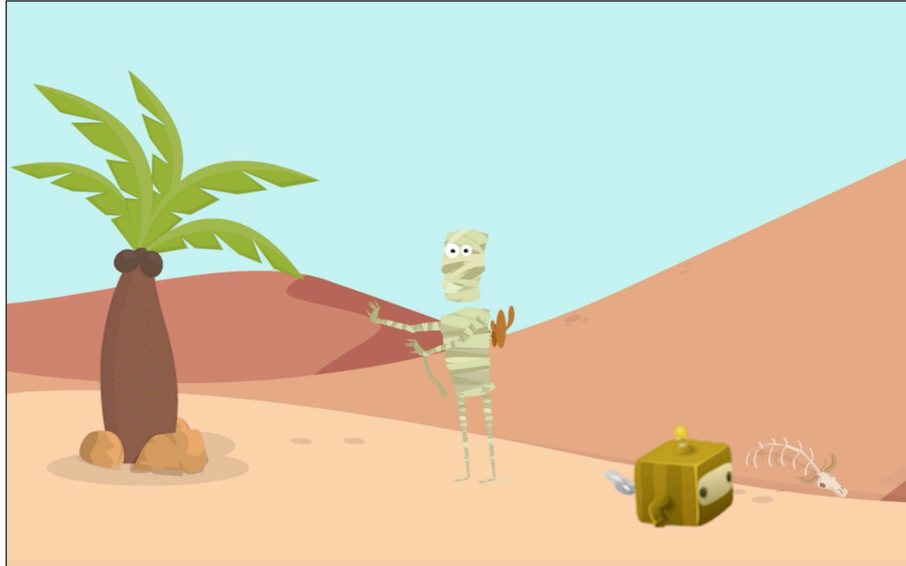

Figure 9: Example test scene.

The participant was asked to identify the missing flying object and produce the singular form of the novel noun. Since the context of the single missing object facilitated a definite interpretation, the participant was expected to produce the singular form with the definite suffix,

as shown in (8). The definite suffix induced gender distinctions. In addition, the participant was asked to produce the possessive pronominal, which elicited gender agreement. The participant's response indicated their choice of nominative singular suffix.

- (8) a. Þarna er lerfu-**r-inn** **minn**.
 there is lerfur.M.DEF.SG my.M.SG
 ‘Here is my lerfur.’
- b. Þarna er bukla-**a-n** **mín**.
 there is bukla.F.DEF.SG my.F.SG
 ‘Here is my bukla.’
- c. Þarna er súf-**Ø-ið** **mitt**.
 there is súf.N.DEF.SG my.N.SG
 ‘Here is my súf.’

Once the participant had produced the test sentence, the video proceeded on to the presentation of the next test item. Prior to the test, the participant received training with real nouns with each of the four plural suffixes (*-ar*, *-ur*, *-Ø*, *-ir*), as shown in **Table 8** in section 6.1.

6.3 Analysis

The data were subjected to inferential statistical analyses to test for significance relations. First, a significance test was conducted with nominative plural forms as an independent variable and nominative singular suffix as a dependent variable. Second, a significance test was conducted with nominative plural forms as an independent variable, gender as a dependent variable and test item as a random variable. Stimulus repetition was coded as a null suffix (*-Ø*). The analyses are based on by-participant proportion of target responses. There were no missing data recorded for either child or adult participants.

6.4 Participants

26 children ($M = 7;0$ years, $SD = 1.33$ years, age range = 6;3–8;2 years; 15 females, 11 males) and 20 adult controls participated in this study. An additional two children participated, but were excluded from analysis due to failure to understand the task or unwillingness to engage with the game. The children were recruited from a primary school in Reykjavík, where the study was conducted. The age range was higher in this study since an initial pilot study on 10 children (age range 3;10–5;0 years) revealed that children resorted to zero responses in the task. This response pattern may suggest that children at this age have difficulties retrieving singular forms on the basis of plural forms. Adult participants were recruited at the University of Iceland, Reykjavík. All participants were native speakers of Icelandic with normal hearing and normal to corrected-to-normal vision. No participant reported to have a history of language delay. Participants provided informed consent.

6.5 Predictions

The predictions for experiment 2 are recapitulated in **Table 10**, for convenience:

Nominative plural suffix	Predicted gender	Predicted nominative singular suffix
<i>-ar</i>	Masculine	<i>-r, -i</i>
<i>-ur</i>	Feminine	<i>-a</i>
<i>-∅</i>	Neuter	<i>-∅</i>
<i>-ir</i>	Indeterminate	Indeterminate

Table 10: Predictions for experiment 2.

6.6 Results

Figures 10–11 visualize the relationship between nominative plural suffix and choice of nominative singular suffix in participants' responses:

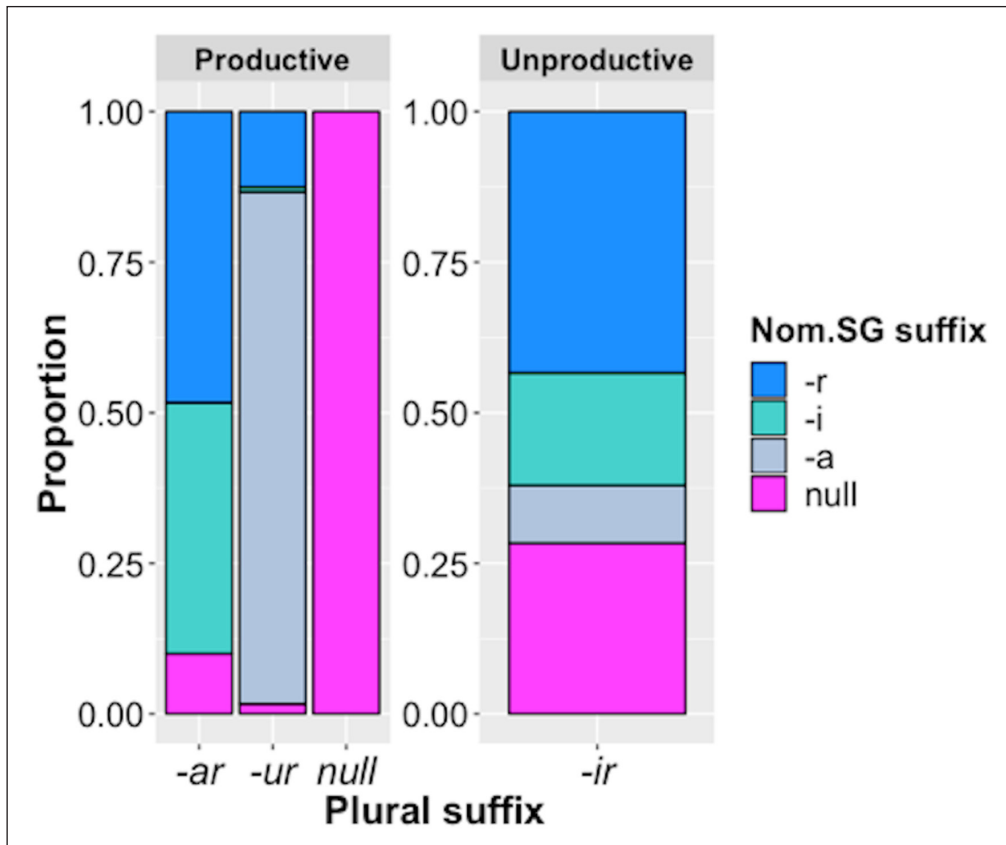

Figure 10: Adults' responses.

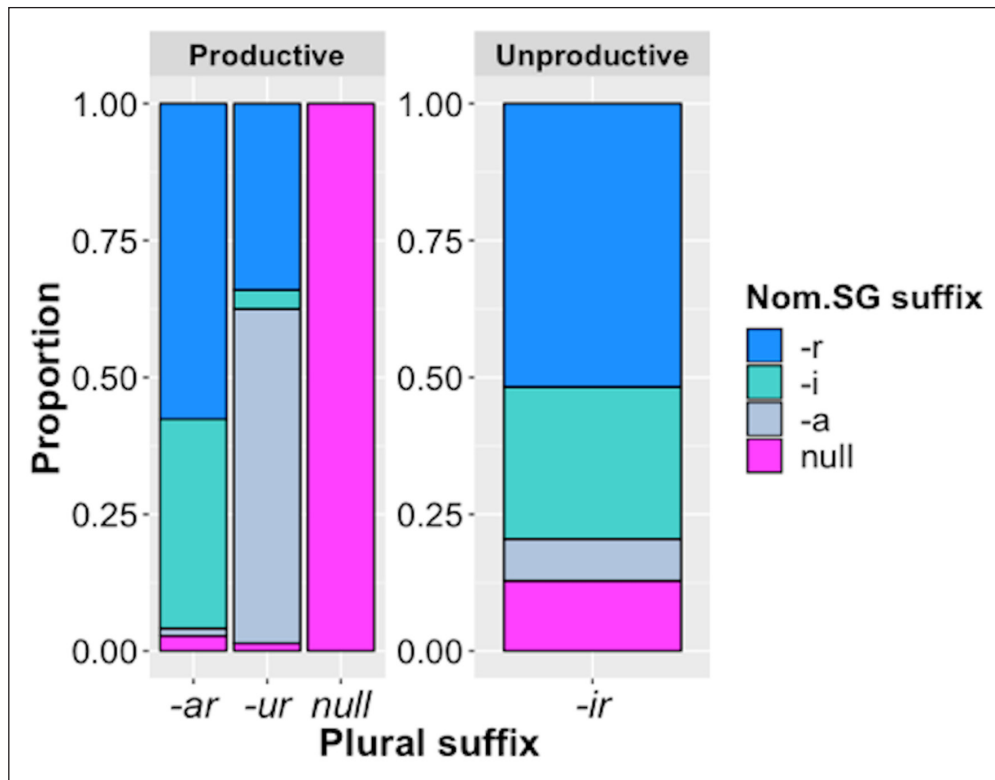

Figure 11: Children's responses.

Adults made a categorical association between productive nominative plural suffixes and corresponding productive nominative singular suffixes. In the productive condition, adults made categorical choices of a nominative singular suffix. Adults chose either nominative singular suffix *-r* ($M = 0.55$, $SD = 0.19$, $SE = .04$) or *-i* ($M = 0.44$, $SD = 0.2$, $SE = .04$) in the case of a novel noun carrying the plural suffix *-ar*. There was no significant difference between the two means ($t(20) = -1.34$, $p = 0.19$). Most adults made a categorical choice of *-a* ($M = 0.85$, $SD = 0.15$, $SE = .03$) for novel nouns with *-ur*. In the case of a null plural suffix, adults always (100%) chose a null nominative singular suffix.

There was no systematic correspondence between *-ir* and any nominative singular suffix. All possible forms were attested with both inter- and intra-speaker variation: *-r* ($M = 0.42$, $SD = 0.17$, $SE = .03$), $-\emptyset$ ($M = 0.35$, $SD = 0.25$, $SE = .06$), *-i* ($M = 0.13$, $SD = .05$, $SE = .01$) and *-a* ($M = 0.1$, $SD = 0.14$, $SE = .03$).

Children were near-categorical in their choice of *-r* as the nominative singular suffix for novel nouns with the plural suffix *-ar* ($M = 0.71$, $SD = 0.29$, $SE = .06$). In the case of a null plural suffix, children always (100%) chose a null nominative singular suffix. Collectively, children were at chance between *-a* ($M = 0.57$, $SD = 0.35$, $SE = .07$) and *-r* ($M = 0.43$, $SD =$

0.35, $SE = .07$) for *-ur*. Five children consistently used *-r* (100%) and four used *-a* (100%). From this we can conclude that the choice of a nominative singular suffix was conditioned by gender. The nominative singular suffix *-r* was the most frequent response in the Unproductive condition ($M = 0.68$, $SD = 0.29$, $SE = .05$).

Figures 12–13 visualize the relationship between gender assignment, as expressed by the definite suffix and possessive pronominal, and plural suffix in participants' responses:

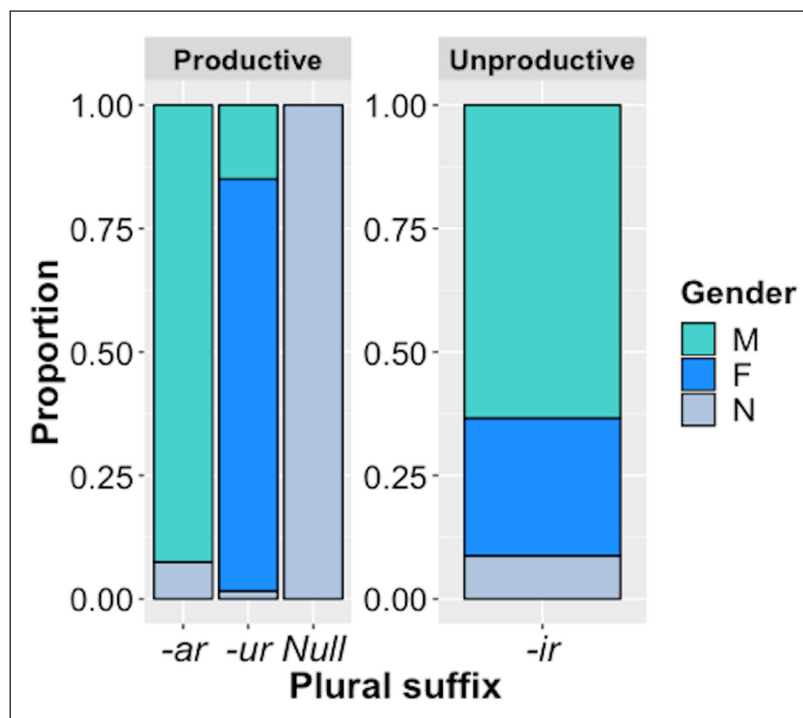

Figure 12: Adults' responses.

Adults made categorical choices of gender in the productive condition. They assigned masculine 97.5% ($SD = .07$, $SE = .02$) of the time to novel nouns with *-ar*. Neuter was used for this plural suffix, on average, 2.5% of the time ($SD = .08$, $SE = .01$), which is not statistically different from zero. Adults chose feminine categorically for *-ur* ($M = 0.87$, $SD = 0.15$, $SE = .03$). Other responses for this suffix consisted of masculine ($M = 0.1$, $SD = 0.16$, $SE = .04$) and neuter ($M = .02$, $SD = .06$, $SE = .0003$). Neuter was always (100%) chosen for novel plural nouns with a null suffix.

Children made a categorical choice of masculine (100%) for novel plural nouns with *-ar*. Likewise, they chose neuter consistently (100%) for novel nouns without an overt plural suffix (null). However, in the case of *-ur*, they were at chance between a choice of masculine ($M = 0.42$, $SD = 0.35$, $SE = .07$) and feminine ($M = 0.58$, $SD = 0.37$, $SE = .07$). The difference between

mean masculine and feminine agreement for this plural suffix was not significant ($t(24) = 1.16$, $p = 0.26$). The high standard deviation for *-ur* suggests differences in children's individual response patterns. Five children used masculine as a default (100%) for this plural suffix and four children used feminine (100%), respectively. There was a significant effect of age on children's percentage feminine responses ($r = 0.68$). In other words, older children were more likely to use feminine agreement with *-ur*. In the unproductive condition, children made a categorical choice of masculine ($M = 0.9$, $SD = 0.1$, $SE = .02$).

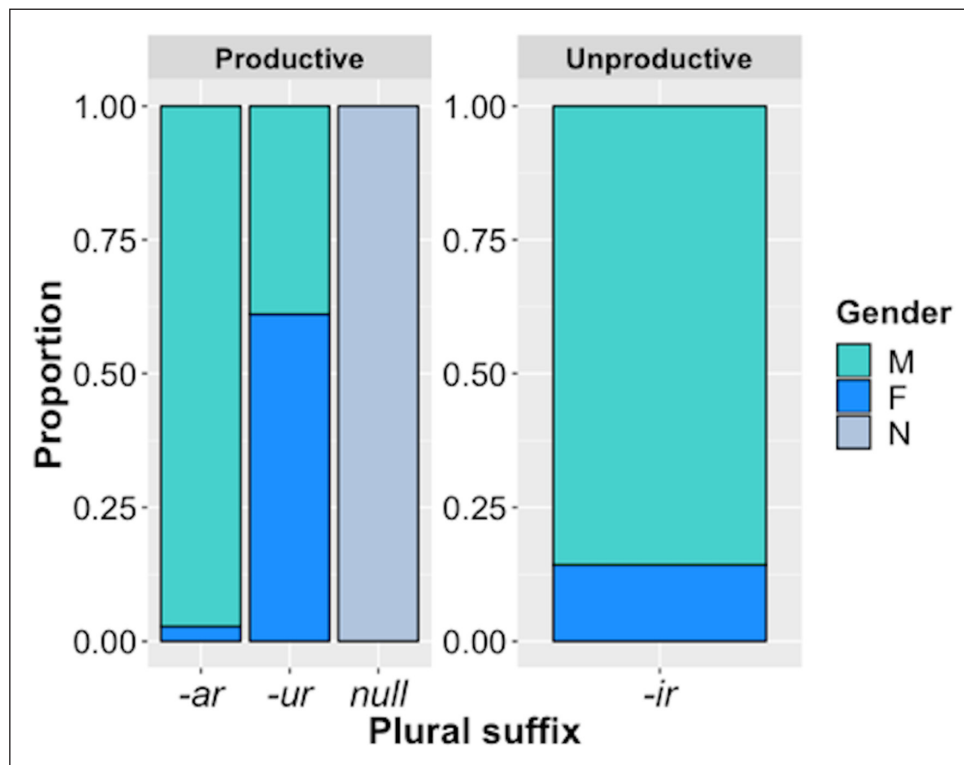

Figure 13: Children's responses.

6.7 Summary and interim discussion

The results indicate that adults can infer the gender and nominative singular form of novel nouns with a productive nominative plural suffix. In the productive condition, adults made categorical choices of gender and nominative singular suffixes: Masculine was consistently assigned and either masculine-productive nominative singular suffix *-r* or *-i* were selected in the case of the plural suffix *-ar*. In parallel, feminine and *-a* were chosen in the case of *-ur*. Finally, neuter and nominative singular \emptyset were invariantly chosen in the case of \emptyset . By contrast, adults did not seem to converge on a systematic generalization in the unproductive condition. Thus, the plural suffix *-ir* did not guide adults' inferences about the gender or inflection of novel nouns.

As a result, adult responses in experiment 2 conformed with the predictions of the Tolerance Principle: In the productive condition, they converged on a systematic generalization, whereas in the unproductive condition, they did not.

Children made a categorical association between *-ar* and masculine and *-ø* and neuter, respectively. However, children's responses were bimodally distributed with respect to the plural suffix *-ur*; some children categorically assigned masculine and selected a masculine-productive nominative singular suffix, while others categorically assigned feminine and selected nominative singular *-a*. The ability to associate nominative plural *-ur* with feminine increased significantly with age. Most masculine nouns that select the nominative singular suffix *-r* get /u/ as the result of an epenthesis process that operates independently of plural formation (see discussion in Footnote 3). Therefore, the masculine nominative singular suffix *-(u)r* may be homophonous with the feminine plural *-ur*. As a result, the association between *-ur* and masculine in younger children may reflect an interference from the homophonous nominative singular suffix *-(u)r*.

In the unproductive condition, children had a clear preference for masculine and masculine-productive nominative singular suffixes, even if *-ir* is more frequent on feminine than masculine nouns. Thus, children's response patterns in the unproductive condition differed from that of adults. While the source of this response pattern is at present unclear, children clearly did not treat *-ir* as a default plural suffix for feminine nouns, contra Wurzel (1987).

7. General discussion

In the present study, I asked how children acquire linguistic categories and their interdependence in fusional noun inflection, using grammatical gender and plural formation in Icelandic as a case study. Since inflectional morphology is a highly language-specific phenomenon, children must somehow be able to extract the relevant generalizations based on the input data. However, the learning task is confounded by data sparsity and children's small vocabulary sizes. In a prior study (Björnsdóttir 2021), productivity – and absence thereof – in nominative singular forms was found to guide both children's and adult's inferences about gender assignment in Icelandic, as predicted by a learning model, the Tolerance Principle (Yang 2005; 2016). In the present study, I asked whether the same conditions could predict productivity – and absence thereof – in plural formation in Icelandic. The model's predictions were borne out, yielding empirical support for the model and interesting theoretical implications.

Learning gender assignment and noun pluralization in Icelandic involves learning nested dependency relations between the two categories with abundant syncretism. The question is why some forms and categories seem to facilitate the induction of others within inflectional paradigms. I argue that children's hypothesis space in the acquisition of inflectional morphology is constrained by the sparsity of the input data. Therefore, I argue that models such as the No Blur Principle (see Carstairs-McCarthy (1994) and a discussion in section 2.1) that assume

that the learner has access to all inflectional forms in acquisition to construct inflectional paradigms are psychologically implausible. Instead, I propose that children establish productive dependency relations between inflectional forms – in this case the nominative singular – to generate the inflectional realizations of novel nouns. Since children will encounter most nouns in the nominative singular in the acquisition of Icelandic, it follows that they will search for productive patterns within that data set.

The role of leading or base forms has been a matter of theoretical dispute. These are forms that seem to carry more weight than others in both acquisition and change. The dispute centers around the question of how these forms are determined: Is their status determined by the language design or does it arise from derivative factors such as frequency or language usage? This question is confounded by the fact that the “leadership” of these forms is not necessarily infallible. Therefore, the challenge consists of determining the conditions for the emergence of leadership in inflectional morphology (see discussion in and references in 2.1). For instance, the nominative singular is standardly assumed to be the leading form in nominal morphology in Icelandic (see Björnsdóttir 2021a; 2021b and references therein). However, as the present study demonstrates, nominative singular forms may – or may not – facilitate the induction of other inflectional forms. As a result, I argue that the notion of leading or base forms is epiphenomenal. The apparent privileged status of some inflectional forms is a direct consequence of data sparsity in acquisition, rather than being a fact about the language design. In other words, so-called leading forms are empirically determined and their status mandated by productivity.

While the results of experiment 1 demonstrate that children can infer both gender and plural formation on the basis of productive nominative singular forms in Icelandic, the child’s lexical experience will likely be skewed in favor of singular forms. Generally speaking, singular forms are used far more frequently than plural forms. For instance, searching the part-of-speech-annotated corpora of child-directed English (MacWhinney 2000), reveals that the ratio between the average noun frequency and average plural frequency is 5.4:1. Thus, nouns occur 84% of the time in the singular and only 16% of the time in the plural in child-directed input. Therefore, the asymmetry between the use of singular and plural forms seems to reflect a robust fact about language usage. This asymmetry may account for why younger children were unable to carry out the task in experiment 2, although the exact source of their difficulties with the task remains at present unclear.

The nature of the interdependence between gender and inflection has been debated: Which category predicts the other and why? Is their interdependence unidirectional, or not (see discussion and references in sections 1 and 2)? In the present study, I demonstrated how productivity in gender assignment correlated with productivity in plural formation in Icelandic. Conversely, I showed how absence of productivity in gender assignment correlated with absence of productivity in plural formation in Icelandic. Since productive singular forms comprise

the basis of grammatical gender acquisition, gender may be a developmental prerequisite for learning plural formation. Therefore, the role of grammatical gender as a “catalyst” in inflectional morphology in Icelandic may derive from the distribution of inflectional forms in the input. This fact may also account for typological patterns in inflectional morphology: Greenberg’s (1966) universals 37 and 45 state that a language only has gender distinctions in the plural if it has gender distinctions in the singular. In other words, all gender systems encode gender in the singular, but only some in the plural. The statistical dominance of singular forms entails that the loss of a productive generalization in the singular entails the loss of a productive generalization in the plural. Therefore, I propose that typological patterns may be explained in terms of the statistical tendencies in language and how they are learned in acquisition. The patterns instantiated by inflectional paradigms consist of both generalizations and idiosyncrasies that have posed significant theoretical challenges. However, once the psychological reality of language acquisition is taken into account, the distribution of inflectional forms follows from a learning process guided by a search for productivity.

8. Conclusion

I have demonstrated how children and adults can infer both gender and plural forms of novel nouns in Icelandic on the basis of productive nominative singular forms, as predicted by a learning model (Yang 2005; 2016). By contrast, the absence of a productive nominative singular form resulted in ineffability in both gender and plural marking. I argue that the relation between gender and inflection is derivative, reflecting data sparsity in acquisition, rather than the language design. The interdependence between the two categories is clearly reflected in the present findings: Productivity in gender assignment correlated with productivity in plural formation. Conversely, absence of productivity in gender assignment correlated with absence thereof in plural formation. As a result, there is no inherent causal dependency relation between the two categories. However, since gender acquisition involves detecting productive singular forms, gender may be a developmental prerequisite for learning plural forms, given the uneven frequency distributions of singular and plural forms. I argue that the present findings illustrate how statistical tendencies in language and learning may shed light on the organizational principles of inflectional paradigms.

Abbreviations

F = feminine, M = masculine, N = neuter, NOM = nominative, PL = plural, SG = singular.

Data availability

The data presented in this article is publicly available at the Open Science Framework via the link <https://osf.io/vke79/>. The data are divided into three components:

- Instrumentation: This component contains the stimuli used for both experimental studies (plural1.mp4 for the first study, plural2.mp4 for the second study).
- Data: This component contains the data obtained in the studies. It has three folders:
 - Corpus analysis: This folder contains data from the Tagged Icelandic corpus that were used to generate predictions for the experimental studies (pluralMIM.csv).
 - Plural Experiment 1: This folder contains data collected from adult (adults_bla.csv) and child (plural_version1_intake.csv) participants in the first experimental study.
 - Plural Experiment 2: This folder contains data collected from adult (plural2_adults.csv) and child (plural2_kids.csv) in the second experimental study.
- Analysis: This component contains two R scripts pertaining to the studies:
 - plural.R: Analysis of child and adult data collected in the first experimental study.
 - plural2.R: Analysis of child and adult data collected in the second experimental study.

Ethics and consent

Ethical approval for all experiments was obtained from the *Norwegian Centre for Research Data* prior to data collection. Informed consent was obtained from the parents of child participants. Adult participants provided informed consent as well.

Acknowledgements

I would like to express my gratitude to three anonymous reviewers whose careful, detailed and constructive comments greatly improved this article. All remaining flaws are mine.

Competing interests

The author has no competing interests to declare.

References

- Ackerman, Farrell & Blevins, James P. & Malouf, Robert. 2009. Parts and wholes: Patterns of relatedness in complex morphological systems and why they matter. In Blevins, James P. & Blevins, Juliette (eds.), *Analogy in Grammar: Form and Acquisition*, 54–82. Oxford: Oxford University Press. DOI: <https://doi.org/10.1093/acprof:oso/9780199547548.003.0003>
- Albright, Adam. 2002. *The identification of bases in morphological paradigms*. Los Angeles, CA: University of California dissertation.
- Albright, Adam. 2004. The Morphological basis of paradigm leveling. In Downing, Laura J. & Hall, Alan & Raffelsiefen, Renate (eds.), *Paradigms in Phonological Theory*. Oxford: Oxford University Press, 17–43. DOI: <https://doi.org/10.1093/acprof:oso/9780199267712.003.0002>
- Alexiadou, Artemis & Müller, Gereon. 2008. Class features as probes. In Bachrach, Asraf & Nevins, Andrew (eds.), *Inflectional Identity*, 101–155. Oxford: Oxford University Press.
- Anderson, Stephen R. 1992. *A-morphous morphology*. Cambridge, MA: Cambridge University Press. DOI: <https://doi.org/10.1017/CBO9780511586262>
- Bauer, Laurie. 2001. *Morphological productivity*. Cambridge: Cambridge University Press. DOI: <https://doi.org/10.1017/CBO9780511486210>
- Berg, Ivar. 2019. Gender and declension mismatches in West Nordic. In Cennamo, Michela & Fabrizio, Claudia (eds.), *Historical Linguistics 2015: Selected paper from the 22nd International Conference on Historical Linguistics, Naples, 27–31 July 2015*, pp. 98–114. Amsterdam: John Benjamins. DOI: <https://doi.org/10.1075/cilt.348.05ber>
- Berko, Jean. 1958. The child's learning of English morphology. *Word* 14 (2–3). 150–177. DOI: <https://doi.org/10.1080/00437956.1958.11659661>
- Björnsdóttir, Sigríður. 2021. Productivity and the acquisition of gender. *Journal of Child Language* 48(6). 1209–1234. DOI: <https://doi.org/10.1017/S0305000920000732>
- Bjorvand, Harald. 1972. Zu den altwestnordischen Pluralendungen -ar, -ir und femininen Substantiva. *Norsk Tidsskrift for Sprogvidenskab [Norwegian Journal of Linguistics]* 26. 195–215.
- Blevins, Julia. 2004. Inflection classes and economy. In Müller, Gereon. & Gunkel, Lutz & Zifonun, Gisela (eds.), *Explorations in Nominal Inflection*, 41–85. Berlin: De Gruyter. DOI: <https://doi.org/10.1515/9783110197501.51>
- Bybee, Joan. 1985. *Morphology: A study of the relation between meaning and form*. Amsterdam: John Benjamins. DOI: <https://doi.org/10.1075/tsl.9>
- Carstairs, Andrew. 1983. Paradigm economy. *Journal of Linguistics* 19(1). 115–128. DOI: <https://doi.org/10.1017/S0022226700007477>
- Carstairs, Andrew. 1987. *Allomorphy in inflexion*. London: Routledge. DOI: <https://doi.org/10.4324/9780203694473>
- Carstairs-McCarthy, Andrew. 1994. Inflection classes, gender and the Principle of Contrast. *Language* 70. 737–787. DOI: <https://doi.org/10.2307/416326>

- Clahsen, Harold. 1999. Lexical entries and rules of language: A multidisciplinary study of German inflection. *Behavioral and Brain Sciences* 22. 991–1069. DOI: <https://doi.org/10.1017/S0140525X99002228>
- Clark, Eve. 1987. The Principle of Contrast: A constraint on language acquisition. In McWhinney, Brian (ed.), *The Mechanism of Language Acquisition*, 1–33. Hillsdale, NJ: Erlbaum.
- Clark, Eve. 1988. On the logic of contrast. *Journal of Child Language* 15. 317–335. DOI: <https://doi.org/10.1017/S0305000900012393>
- Clark, Eve. 1990. On the pragmatics of contrast. *Journal of Child Language* 17. 417–431. DOI: <https://doi.org/10.1017/S0305000900013842>
- Corbett, Greville. 1991. *Gender*. Cambridge, UK: Cambridge University Press.
- Dabrowska, Eva. 2001. Learning a morphological system without a default: The Polish genitive. *Journal of Child Language* 28. 225–271. DOI: <https://doi.org/10.1017/S0305000901004767>
- Dabrowska, Eva. 2005. Productivity and beyond: mastering the Polish genitive inflection. *Journal of Child Language* 32(1). 191–205. DOI: <https://doi.org/10.1017/S0305000904006609>
- Doleschal, Ursula. 2000. Gender assignment revisited. In Unterbeck, Barbara & Risanen, Matti (eds.), *Gender in Grammar and Cognition. Part I*, 117–166. Berlin: De Gruyter. DOI: <https://doi.org/10.1515/9783110802603.117>
- Enger, Hans-Olav. 2004. On the relation between gender and declension, a diachronic perspective from Norwegian. *Studies in Language* 28(1). 51–82. DOI: <https://doi.org/10.1075/sl.28.1.03eng>
- Gíslason, Indriði & Konráðsson, Sigurður & Jóhannesson, Benedikt. 1986. *Framburður og myndun fleirtölu hjá 200 íslenskum börnum við fjöggra og sex ára aldur* [Pronunciation and plural formation in 200 four-to-six-year-old Icelandic children]. Reykjavík: Rit Kennaraháskóla Íslands [Department of Education at the University of Icelandic Publishing].
- Greenberg, Joseph. H. 1966. *Universals of language*. Cambridge, MA: MIT Press.
- Hahn, Ulrike & Nakisa, Ramin C. 2000. German inflection: Single route or dual route? *Cognitive Psychology* 41. 313–360. DOI: <https://doi.org/10.1006/cogp.2000.0737>
- Halle, Morris & Marantz, Alec. 2008. Clarifying “Blur”: Paradigms, defaults and inflectional classes. In Bachrach, Asraft & Nevins, Andrew (eds.), *Inflectional Identity*, 55–72. Oxford: Oxford University Press.
- Hart, Betty & Risley, Todd. 1995. *Meaningful differences in the everyday experience of young American children*. Baltimore, MD: Paul H. Brookes Publishing.
- Hart, Betty & Todd, R. Risley. 2003. The early catastrophe: The 30-million-word gap by age 3. *American Educator* 27(1). 4–9. DOI: <https://doi.org/10.1177/074193259801900609>
- Helgadóttir, Sigrún & Svavarsdóttir, Ásta & Rögnvaldsson, Eiríkur & Bjarnadóttir, Kristín & Loftsson, Hrafn. 2012. The Tagged Icelandic Corpus (MÍM). *Proceedings of the Workshop on Language Technology of under-resourced languages*, 67–72.
- Iversen, Ragnvald. 1972. *Norrøn grammatikk*. (7th edition). Oslo: Aschehough.

- Jónsdóttir, Margrét. 1988–1989. Um ir- og ar- fleirtölu einkvæðra kvenkynsorða í íslensku. [On the pluralization feminine monosyllabic nouns in Icelandic]. *Íslenskt mál og almenn málfræði* 10–11. 57–83.
- Karmiloff-Smith, Annette. 1979. *A functional approach to child language, A study of determiners and reference*. Cambridge, UK: Cambridge University Press.
- Kauschke, Christina & Kurth, Anna & Domahs, Ulrike. 2011. Acquisition of German noun pluralization in typically developing children and children with specific language impairment. *Child Development Research*. DOI: <https://doi.org/10.1155/2011/718925>
- Kodner, Jordan. 2019. Estimating child linguistic experience from historical corpora. *Glossa: A journal of General Linguistics* 4(1): 122. DOI: <https://doi.org/10.5334/gjgl.926>
- Kramer, Ruth. 2015. *The morphosyntax of gender*. Oxford, UK: Oxford University Press. DOI: <https://doi.org/10.1093/acprof:oso/9780199679935.001.0001>
- Kürschner, Sebastian & Nübling, Damaris. 2011. The interaction of gender and declension in Germanic languages. *Folia Linguistica* 45(2). 355–388. DOI: <https://doi.org/10.1515/flin.2011.014>
- Kvaran, Guðrún. 2005. *Orð. Handbók um beygingar- og orðmyndunarfræði* [Words. A Handbook of Icelandic inflection and derivation.] Reykjavík: Almenna bókafélagið.
- Lahiri, Aditi. & Dresher, Bezalel. 1983. Diachronic and synchronic implications of declension shifts. *The Linguistic Review* 3(2). 141–163. DOI: <https://doi.org/10.1515/tlir.1983.3.2.141>
- Lignos, Constantine & Yang, Charles. 2016. Morphology and language acquisition. In Hippisley, Andrew & Stump, Gregory (eds.), *The Cambridge Handbook of Morphology*, 765–791. Cambridge, UK: Cambridge University Press. DOI: <https://doi.org/10.1017/9781139814720.027>
- MacWhinney, Brian. 2000. *The CHILDES project: Tools for analyzing talk: Transcription format and programs (3rd Edition)*. Hillsdale, NJ: Lawrence Erlbaum Associates Publishers.
- Matthews, Peter. 1991. *Morphology*. Cambridge, UK: Cambridge University Press.
- Mills, Anne. 1986. *The acquisition of gender: A study of English and German grammatical development*. Berlin: Springer.
- Neset, Tore. 2003. The assignment of gender and declension to Russian nouns in Soft Consonants: Predictability and Rule Interaction. *Journal of Slavic Linguistics* 11(2). 287–322. <https://www.jstor.org/stable/24599593>.
- Pérez-Pereira, Miguel. 1991. The acquisition of gender: What Spanish children tell us. *Journal of Child Language* 18(3). 571–590. DOI: <https://doi.org/10.1017/S0305000900011259>
- Pinker, Stephen. 1999. *Words and rules: The ingredients of language*. New York, NY: Basic Books.
- Rodina, Yulia & Westergaard, Marit. 2012. A cue-based approach to the acquisition of grammatical gender in Russian. *Journal of Child Language* 39. 1077–1106. DOI: <https://doi.org/10.1017/S0305000911000419>
- Rodina, Yulia & Westergaard, Marit. 2015. Grammatical gender in Norwegian: Language acquisition and language change. *Journal of Germanic Linguistics* 27(2). 145–187. DOI: <https://doi.org/10.1017/S1470542714000245>

- Rögnvaldsson, Eiríkur. 2013. *Hljóðkerfi og orðhlutakerfi íslensku* [The phonology and morphology of Icelandic]. Available at https://notendur.hi.is/eirikur/hh_2013.pdf.
- Slobin, Dan. 1977. Language change in childhood and history. In Macnamara, John (ed.), *Language Learning and Thought*, 165–213. Cambridge, MA: Academic Press.
- Spencer, Andrew. 2002. Gender as an inflectional category. *Journal of Linguistics* 38(2). 279–312. DOI: <https://doi.org/10.1017/S0022226702001421>
- Steinmetz, Donald. 1985. Gender in German and Icelandic: Inanimate nouns. In Faarlund, Jan Terje (ed.), *Germanic Linguistics. Papers from a symposium at the University of Chicago*, 44–69. Bloomington: Indiana University Linguistics Club.
- Stump, Gregory T. 2001. *Inflectional morphology, a theory of paradigm structure*. Cambridge, UK: Cambridge University Press. DOI: <https://doi.org/10.1017/CBO9780511486333>
- Stump, Gregory & Finkel, Raphael. 2009. Principal parts and degrees of paradigmatic transparency. In *Analogy in Grammar*. Oxford: Oxford University Press. DOI: <https://doi.org/10.1093/acprof:oso/9780199547548.003.0002>
- Szagan, Gisela & Steinbrink Claudia & Franik, Melania & Stumper, Barbara. 2006. Development of vocabulary and grammar in young German-speaking children assessed with a German language development inventory. *First Language* 26(3). 259–280. DOI: <https://doi.org/10.1177/0142723706056475>
- Thomas, Enlli & Mueller Gathercole, Virginia. 2007. Children's productive command of grammatical gender and mutation in Welsh: An alternative to rule-based learning. *First Language* 27(3). 251–278. DOI: <https://doi.org/10.1177/0142723707077056>
- Thráinsson, Höskuldur. 2017. U-umlaut in Icelandic and Faroese: Survival and death. In Horn, Laurence & Bowerman, Claire & Zanuttini, Rafaela (eds.): *On looking into words (and beyond)*, 99–113. Berlin: Language Science Press.
- Tomasello, M. 2003. *Constructing a language*. Cambridge, MA: Harvard University Press.
- Wurzel, Wolfgang Ullrich. 1987. Paradigmenstrukturbedingungen: Aufbau und Veränderung von Flexionsparadigmen. In Ramat, Anna Giacalone & Carruba, Onofrio & Bernini, Gualiano (eds.): *Papers from The 7th International Conference on Historical Linguistics*, 135–155. Amsterdam: Benjamins.
- Wurzel, Wolfgang Ullrich. 1998. Drei Ebenen der Struktur von Flexionsparadigmen. In Ray Fabri, Ray & Ortmann, Albert & Parodi, Teresa (eds.): *Models of Inflection*, 225–243. Berlin: De Gruyter. DOI: <https://doi.org/10.1515/9783110919745.225>
- Yang, Charles. 2005. On productivity. *Linguistic Variation Yearbook* 5(1). 333–370. DOI: <https://doi.org/10.1075/livy.5.01van>
- Yang, Charles. 2016. *The price of linguistic productivity: How children learn to break rules of language*. Cambridge MA: MIT Press. DOI: <https://doi.org/10.1075/livy.5.09yan>
- Zipf, George. 1949. *Human behavior and the principle of least effort: An introduction to human ecology*. Cambridge, MA: Addison-Wesley.

